

MATERIAL OPTIONS

- CLASS 1 COPPER/ZIRCONIUM C15000
- CLASS 2 COPPER/CHROMIUM C18200
- CLASS 2 COPPER/CHROMIUM/ZIRCONIUM C18150
- CLASS 3 COPPER/NICKEL/BERYLIUM C17510
- REFRACTORY METALS AVAILABLE UPON REQUEST

WHEEL DIMENSIONS

WT: _____

R: _____

D1: _____

D2: _____

D3: _____

F: _____

W: _____

X: _____

P: _____

PD: _____

BC: _____

N: _____

T: _____

MAT'L: _____

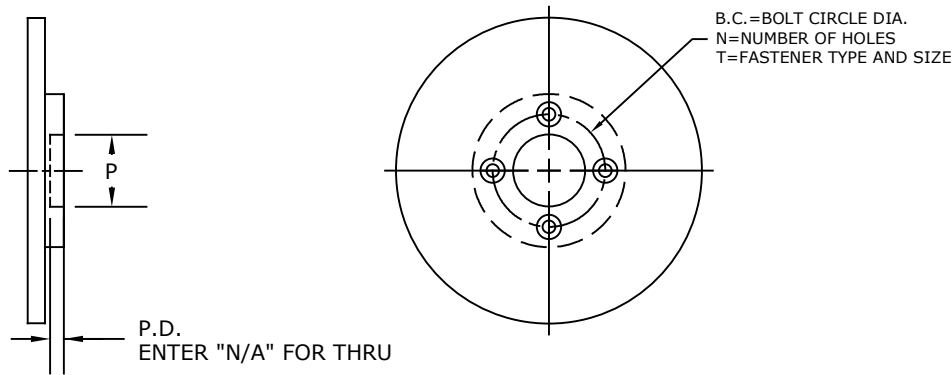

NOTES:

SEAM WELD WHEEL ORDER FORM



buy online
RWElectrodes.com
 866-RES-WELD

UNLESS OTHERWISE SPECIFIED,
 TOLERANCES:
 FRACTIONS=±1/32
 DEC .XX=±.015
 DEC .XXX=±.005
 ANGLES=±1/2°

SEEDORFF ACME CORP.
 RESISTANCE WELDING EQUIPMENT
 TEL. 714-252-5330
 FAX 714-252-5335
 1338 N. KNOLLWOOD CIRCLE, ANAHEIM, CA

SCALE	DWG. SIZE	DWG. NO.	REV.
NONE	A		