

WHEEL TYPE 1 (SIDE VIEW)

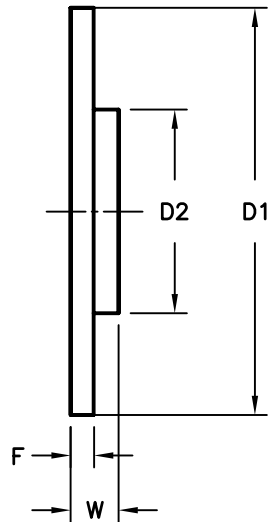

WHEEL TYPE 2 (SIDE VIEW)

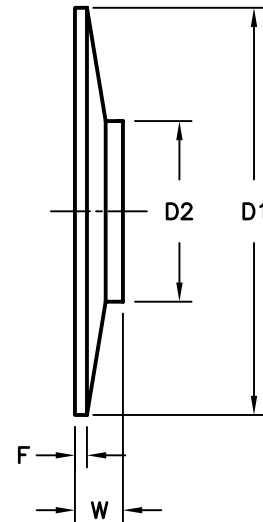

WHEEL TYPE 3 (SIDE VIEW)

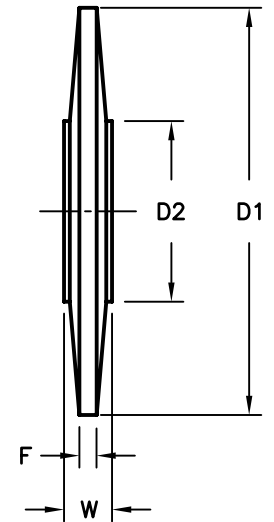

WHEEL TYPE 4 (SIDE VIEW)

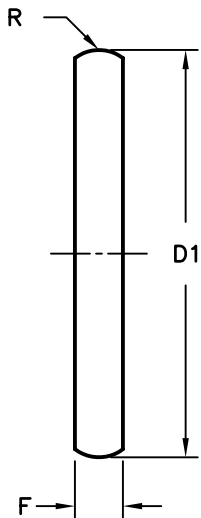

WHEEL TYPE 1R (SIDE VIEW)

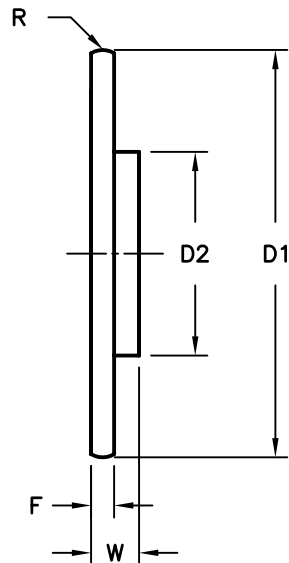

WHEEL TYPE 2R (SIDE VIEW)

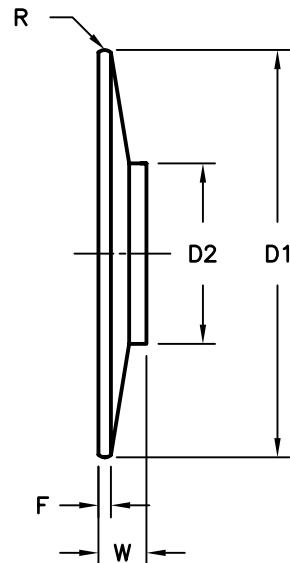

WHEEL TYPE 3R (SIDE VIEW)

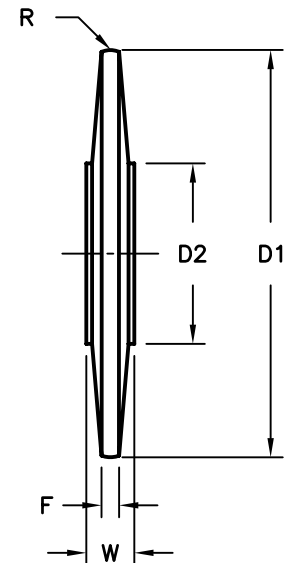

WHEEL TYPE 4R (SIDE VIEW)

STEP ONE: CHOOSE WHEEL TYPE

WT=WHEEL TYPE, R=RADIUS, D1=WHEEL DIA.,
D2=HUB DIA., F=WELD FACE, W=WHEEL THICKNESS.

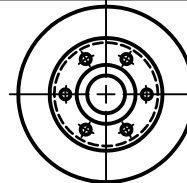

UNLESS OTHER-
WISE SPECIFIED,
TOLERANCES:
FRACTIONS= $\pm 1/32$
DEC .XX= $\pm .015$
DEC .XXX= $\pm .005$
ANGLES= $\pm 1/2^\circ$

A.P. SEEDORFF & CO., INC.
RESISTANCE WELDING EQUIPMENT
TEL. 714-252-5330
FAX 714-252-5335
1338 N. KNOLLWOOD CIRCLE, ANAHEIM, CA

SCALE
NONE

DWG. SIZE
A

DWG. NO.
6200 (1 OF 2)

REV.

STEP 2: PILOT TYPE AND DIAMETER

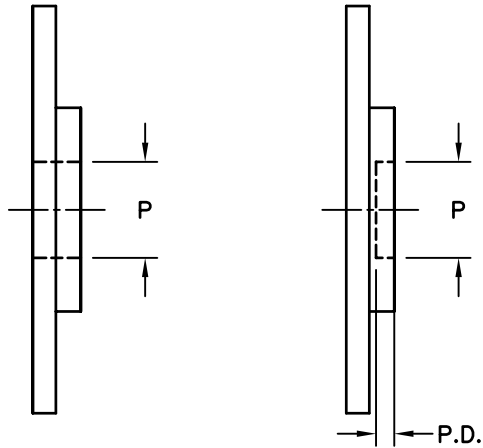

STEP 4: SELECT MATERIAL

- CLASS 1 COPPER, ZIRCONIUM
- CLASS 2 COPPER, CHROMIUM, ZIRCONIUM
- CLASS 3 COPPER, NICKEL, BERYLLIUM
- CLASS 11 TUNGSTEN COPPER (ELKONITE 10W3)
- CLASS 13 TUNGSTEN COPPER (ELKON 100W)

STEP 5: CONFIGURE WHEEL

WT: _____

R: _____

D1: _____

D2: _____

F: _____

W: _____

P: _____

PD: _____

BC: _____

N: _____

T: _____

MAT'L: _____

STEP 3: MOUNTING DEFINITION

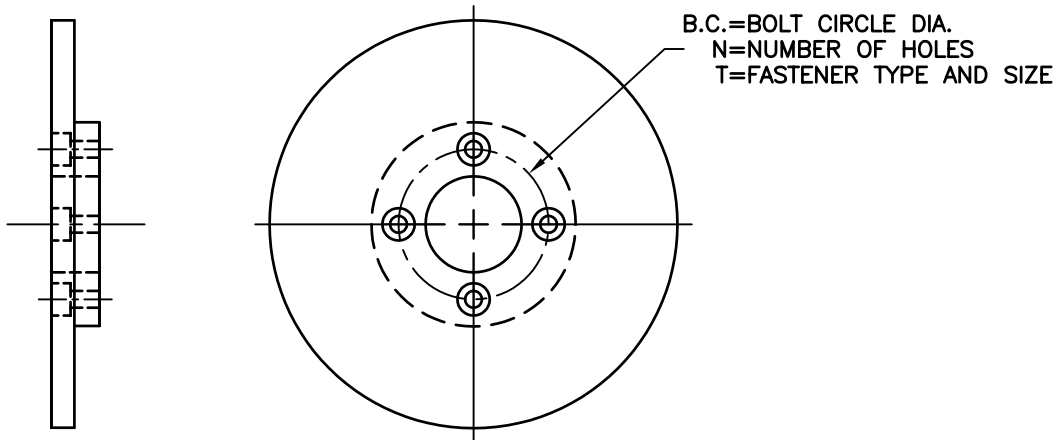

NOTES:

STEP TWO: PILOT TYPE

P=PILOT DIA., PD=PILOT DEPTH.

STEP THREE: MOUNTING TYPE AND BOLT CIRCLE DEFINITION

B.C.=BOLT CIRCLE DIA., N=NUMBER OF HOLES, T=FASTENER TYPE AND SIZE.

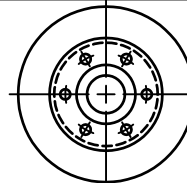

UNLESS OTHER-
WISE SPECIFIED,
TOLERANCES:
FRACTIONS=±1/32
DEC .XX=±.015
DEC .XXX=±.005
ANGLES=±1/2°

A.P. SEEDORFF & CO., INC.
RESISTANCE WELDING EQUIPMENT
TEL. 714-252-5330
FAX 714-252-5335
1338 N. KNOLLWOOD CIRCLE, ANAHEIM, CA

SCALE	DWG. SIZE	DWG. NO.	REV.
NONE	A	6200 (2 OF 2)	